

FIGHTER 280

6x2 FU281R7

6x2 FU281R8



FU281R7/R8

*NOMINAL PAYLOAD	GVM	GCM	POWER	W/BASE	CODE
8.0T FU281R7	18,000kg	25,000kg	280ps	6,210mm	FM65FM2RFAA
11T FU281R8	22,400kg	25,000kg	280ps	6,210mm	FM65FM2RFAA

* Subject to weight of body fitted

PERFORMANCE (Calculated – Paved Road)

Maximum Speed:	100km/h
Gradeability at Rated GVM:	23.5%
Gradeability at Rated GCM:	21%
Turning Circle (kerb to kerb):	20.4m

ENGINE

Model: 6M60-3AT2 Diesel (ADR 80/02)
Configuration: 6 cyl. in-line OHC, 4-valve
Type: Turbocharged and intercooled with quick heat glow plugs and cooled EGR
Displacement: 7,545cc
Bore: 118mm
Stroke: 115mm
Power (JIS Gross): 207kW (281ps) @ 2,600rpm
Torque (JIS Gross): 802Nm (592lb/ft) @ 1,400rpm
Maximum Engine Speed: 2,900rpm
Compression Ratio: 18:0:1
Oil Cooler: Plate type, water cooled
Meets EPA04 exhaust emission standards

6M60-3AT2 ENGINE MODEL

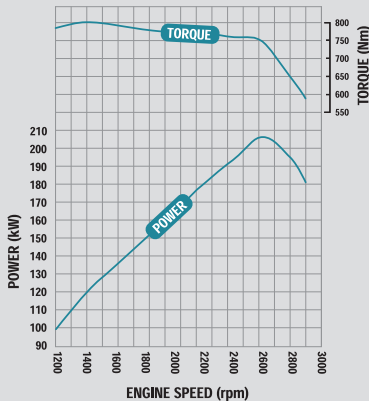

FUEL

Injection System: DENSO common rail system
Governor: Electronic, speed limited to 100km/h
Controls: Key operated start/fuel
 Emergency stop
Filtration: Main filter and water separator
Fuel Capacity: 300 litres with lockable fuel cap
Air Cleaner: Dual element Cyclopac with vertical intake and air restriction indicator
Muffler: Catalytic convertor with oxidation catalyst

COOLING

Fan: 540mm dia. 10 blades
Fan Drive: Thermo modulated
Radiator: Corrugated fin with expansion tank

ELECTRICAL

Voltage: 24V negative earth
Alternator Capacity: 24V-50 amp
Starter Capacity: 24V-5.0kW
Battery Capacity: Heavy duty 2 x 12V, 100Ah/20hr
Headlamp – Type: Halogen
 – Capacity: Low beam 2 x 70W
 High beam 2 x 75W

CLUTCH

Model: C7M38
Disc Diameter: 380mm
Type: Single dry plate
Operation: Air assisted hydraulic
Facing Area: Cerametallic – 754cm²

TRANSMISSION

Model: M070S6-D
No. of Speeds: 6 with air assisted gearshift
Synchromesh: 2nd-6th
 1: 8.064
 2: 5.443
 3: 3.064
 4: 1.824
 5: 1.321
 6: 1.000
Reverse: 7.354
PTO Opening: LH side

PROPELLER SHAFT

Type: P10
Universal Joint: Needle roller

FRONT AXLE

Model: F070T
Type: Reverse Elliot 'I' beam
Design Capacity: 6,300kg
Maximum Operating Capacity: 6,300kg

REAR AXLE

Front Rear Axle: R060T/D8H
Type: Full floating hypoid
Design Capacity: 10,200kg
Maximum Operating Capacity: 10,200kg
Ratio: 4.444
Lazy Axle:
Type: Hendrickson HTA11
Type: Solid drawn torsion Beam
Maximum Operating Capacity: 11,360kg
Maximum Combined Operating Capacity: 18,000kg

STEERING

Type: Integral power assisted – ball & nut
Ratio: 22.4:1
Steering Wheel: 450mm energy absorbing urethane
Steering Column: Tilt/telescopic adjustable with lock

BRAKES

Type: Full air, dual circuit, Mitsubishi taper roller with automatic brake adjustment & ABS
Size: Front: 410 x 150mm
 Rear: 410 x 200mm
 Lazy Axle: 410 x 200mm
Lining: Asbestos free: area/swept – 5,820/9,020 cm²
Park Brake: Rear wheel spring actuated
Auxiliary: Exhaust brake
Compressor: Water cooled, 319cc single cylinder high output
Air Dryer Model: DU-3

FRONT SUSPENSION

Type: Long taper leaf
Size: 1,400 x 80 x 18mm – 1 leaf
 x 22mm – 2 leaves
Capacity at Ground: 3,665kg each
Shock Absorbers: Double acting

REAR SUSPENSION

Type: Hendrickson HAS 400 air suspension shock absorbers – double acting front & rear
Capacity at Ground: 18,000kg

CHASSIS

Type: Parallel channel
Size: 280 x 90 x 8.0mm
Width: 841mm
Tensile Strength: 540Mpa

Refer to FUSO bodybuilder guidelines on web site www.fuso.co.nz/fightrbodies before mounting a body or modifying the chassis.



WHEELS & TYRES

Wheel:	Type:	7, Single piece disc
	Size:	22.5 x 8.25DC-165-12t
	Stud pattern:	10 x 335mm PCD
Tyre:	Size:	275/70R22.5 148/145K
Spare Tyre Carrier:		Provided

KERB WEIGHT (kg – estimated)

Front:	Rear:	Total:
3,050kg	2,440kg	5,490kg

Includes coolant, oils, spare wheels, tools and 20 litres fuel.

CAB FEATURES

Construction:	All steel forward control
Type:	Manual tilt 44 degrees
Mounting:	Hydroelastic suspension 4 point
Colour:	Natural White
Interior:	Fully trimmed with vinyl floor mat
Windscreen:	Laminated tinted
	Tinted side and rear glass
Windscreen Wipers:	2 speed – intermittent cycle
Transom Window on LH Door	
Rear Vision Mirrors:	Heated with extended arms
Lift-up Front Maintenance Panel	
Cab & engine side covers for noise reduction	
Front Bumper Air Dam	
White Roof Outline Marker Lamps:	2
Roof Mounting Points (max. static load 50kg)	
Seating Capacity:	3
Seat Belts:	2 ELR lap sash, 1 lap
Seats: Driver:	Air suspension with auto levelling height control, 32 stage reclining, 11 stage sliding, front and rear height adjuster, lumbar support, integral headrest and fabric trim
Centre:	Low back with fabric trim, forward folding
LH:	Fixed base, 32 stage reclining, integral headrest and fabric trim

INSTRUMENTS

Gauges:

- Speedometer with odometer & dual trip meter
- Tachometer
- Air pressure (2)
- Fuel level
- Water temperature
- Digital clock

Warning Lamps:

- Turn signal
- High beam
- Exhaust brake
- Park brake
- Glow plug indicator
- Alternator
- Oil filter blockage
- Engine control/Cruise control (ECU)
- Air filter restriction
- Door
- Cab tilt

Warning Lamps/Buzzers:

- Air pressure
- Oil pressure
- Engine overheat/low coolant level

REAR SUSPENSION

Type:	Hendrickson HAS 400 air suspension shock absorbers – double acting front & rear
Capacity at Ground:	18,000kg

STANDARD EQUIPMENT

- Electric windows
- Keyless central locking
- Cruise control
- Air conditioner/heater demister
- AM/FM ETR radio and CD player
- Centre seat storage console
- LH seat storage tray
- Overhead storage pocket with lid
- RH door storage pocket
- Rear bunker storage pockets
- Cup holders x 2
- Opening rear quarter windows
- Interior sun visors
- Fluorescent cabin lamp
- Interior and map reading lamps
- Windscreen washers
- Hazard warning lamps
- Oil level check switch
- Cigarette lighter/accessories plug
- Electric horn
- Reverse warning buzzer
- Toolkit
- Chassis mounted toolbox

WARRANTY

Vehicle: 36 Months/200,000 km*

*Which ever comes first subject to the terms and conditions detailed in the warranty book.

FIGHTER 280
6x2 FU281R7
6x2 FU281R8

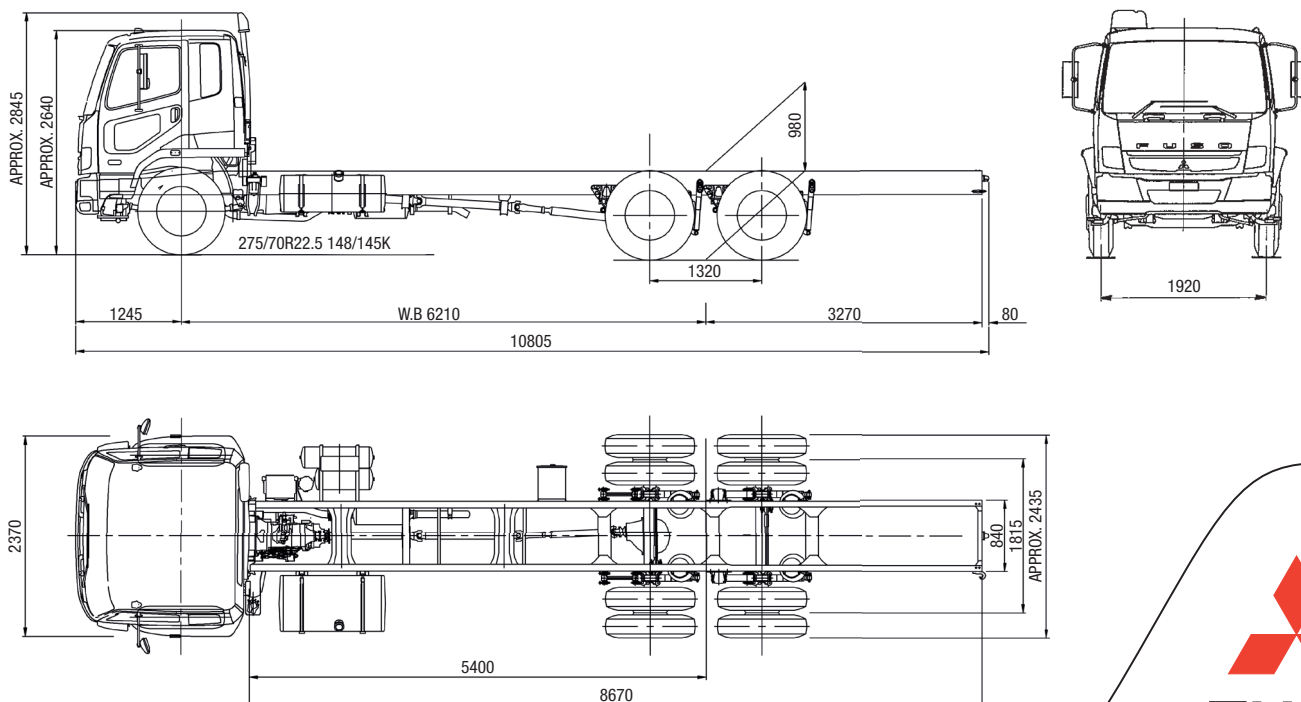

A policy of continual improvement means that specifications detailed in this brochure are subject to change without notice. Your Mitsubishi FUSO Dealer will be able to confirm the exact current specifications.

