

FIGHTER 190

4x2 FK190K5

*NOMINAL PAYLOAD	WB	KERB WEIGHT EST.	GVM	GCM	CODE
5.5T	4870mm	3260kg	10600kg	15000kg	FK617KJRFBA

* Subject to weight of body fitted

PERFORMANCE	
Maximum Speed:	124km/h
Gradeability at GVM:	36.5%
Gradeability at GCM:	24.5%
Minimum Turning Radius:	8.4m (kerb to kerb)

ENGINE	
Model:	6D16-1A
Configuration:	6 cyl in line
Type:	4 cycle direct injection
Displacement:	7545cc
Bore:	118mm
Stroke:	115mm
Power (JIS):	140kW (190ps) @ 2900rpm
Torque (JIS):	520Nm (383lb/ft) @ 1400rpm
Maximum Engine Speed:	3100rpm
Compression Ratio:	18.0:1
Oil Cooler:	Plate type – water cooler
Dry Weight:	507kg

FUEL	
Pump:	ZEXEL 'A' type
Governor:	All speed type
Tank Capacity:	130 litres
Filter:	In line filter with water separator
Fuel Cap:	Lockable

COOLING	
Fan:	6 blades – 480mm outer diameter
Fan Drive:	Viscous
Radiator:	Corrugated fin type with pressure cap & water reservoir

ELECTRICAL	
Voltage:	24v
Alternator Capacity:	35 amp
Starter Capacity:	4.5kW
Battery:	2 x 12v, 100Ah/20hr

CLUTCH	
Model:	C6W35
Diameter:	350mm
Type:	Single dry plate
Operation:	Hydraulic control
Facing Area:	1164 sq cm
Facing Material:	Woven
Facing Thickness:	4.5mm

TRANSMISSION	
Model:	M060S6-0D
No of Speeds:	6 forward 1 reverse
1.	Constant mesh 6.875
2.	Synchromesh 4.189
3.	Synchromesh 2.460
4.	Synchromesh 1.542
5.	Synchromesh 1.000
6.	Synchromesh 0.786
Reverse:	Constant mesh 6.875
Control:	Floor shift mechanical remote

PROPELLER SHAFT	
Type:	P4 tubular – forged steel ends with centre bearing
Universal Joint:	Needle roller bearing

REAR AXLE	
Model:	D050H
Type:	Fully floating – hypoid
Design Capacity:	7700kg
Maximum Operating Capacity:	7000kg
Ratio:	4.875:1

FRONT AXLE	
Type:	F040T reverse Elliot
Design Capacity:	3600kg
Maximum Operating Capacity:	3600kg

STEERING	
Type:	Power assisted – ball & nut
Gear Ratio:	17.1-20.0 :1 variable
Steering Wheel Diameter:	500mm
Steering Column:	Tilt & telescopic adjustable

BRAKES	
Type:	Air over hydraulic
Size:	F 320 x 120 x 12mm R 320 x 140 x 12mm
Total Lining Area:	3224 sq cm
Park Brake:	Spring
Auxiliary:	Exhaust
Compressor:	Single cylinder
Displacement:	201cc
Air Dryer:	Standard

SUSPENSION	
Type Front:	Semi elliptic leaf
Size:	1300 x 70 x 10mm – 9
Type Rear:	Semi elliptic leaf
Size:	1300 x 70 x 11mm – 10
Helper:	900 x 70 x 10mm – 8
Shock Absorbers:	Front only

CHASSIS	
Type:	Channel section with rivetless top flange
Size:	228 x 80 x 7mm
Width:	840mm
Towing Hook:	Rear
<i>Refer to FUSO bodybuilder guidelines on web site www.mmnztruckdwg.co.nz before mounting a body or modifying the chassis.</i>	

KERB WEIGHT		
Front:	Rear:	Total:
2240kg	1220kg	3260kg
<i>Includes coolant, oils, 20 litres fuel.</i>		

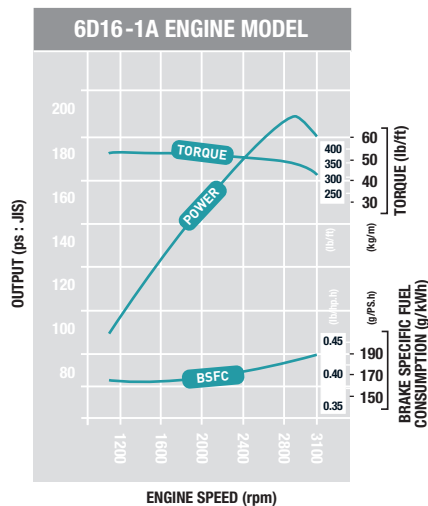

FIGHTER 190 4x2 FK190K5



WHEELS & TYRES

Number:	7
Studs:	6
Size:	17.5 x 6.00 – 135 offset – 9T
Tyre Size:	9.5R17.5 129/127M
Tyre Type:	Tubeless steel radial

CAB FEATURES

Construction:	All steel forward control
Type:	Manual tilt 44 deg
Mounting:	Fully isolated 3 point
Colour:	Natural White (W31)
Windscreen:	Laminated
• Lift-up front maintenance panel	
• Transom window on LH door	
• Roof spoiler mounting points (max weight 50kg)	

DIMENSIONS

Wheel Base (WB):	4870mm
Overall Length (OAL):	8175mm
Cab to Axle (CA):	4015mm
Cab to End of Frame (CE):	6105mm
Rear Overhang (ROH):	2090mm
Overall Height (OAH):	2485mm
Overall Width (OAW):	2170mm
Front Track (FT):	1780mm
Rear Track (RT):	1660mm
Chassis Height at Rear Axle:	910mm

INSTRUMENTS

Gauges:

- Speedometer with odometer & trip meter
- Tachometer
- Air pressure
- Fuel
- Water temperature

Warning Lamps:

- Brake fluid level
- Park brake
- Oil pressure/filter blockage
- High beam
- Turn indicator
- Glow plug indicator
- Exhaust brake
- Engine oil level
- Vacuum pressure
- Alternator
- Air pressure/dual circuit
- Low oil pressure/filter blockage
- Engine overheat/low coolant level
- Door open
- Cab tilt

Warning Buzzers:

- Air pressure
- Oil pressure
- Engine overheat/low coolant level

CAB EQUIPMENT

Exterior:

- Halogen headlamps
- Fog lamps in bumper
- Heated rear vision mirrors
- Windscreen wipers: 2 speed & intermittent

Interior:

- Fully trimmed
- Floor carpet with driver's mat insert
- Seating capacity for 3
- Seats: Driver: Air suspension, 32 stage reclining, 11 stage sliding, front & rear height adjuster, lumbar support, headrest, fabric trim

Centre: Low back with fabric trim, forward folding

LH: Fixed base, 32 stage reclining, headrest, fabric trim

- Seat Belts: 2 x ELR lap sash, semi integrated type, 1 x lap
- Centre floor console
- Console on back of centre seat
- Glove box x 2
- Door pockets
- Cup holders
- Overhead console pockets
- Sunvisors x 2
- Factory air conditioning
- Heater/demister
- Central locking
- Power windows
- AM/FM radio cassette with clock & 2 speakers
- Steering lock
- Key operated stop/start
- Engine idle speed control
- Cold start switch
- Reverse warning buzzer
- Hazard warning switch
- Interior spot lights
- Cigarette lighter & ash tray
- Electric horns
- Tool kit & jack
- Chassis mounted tool box

FIGHTER 190

4x2 FK190K5

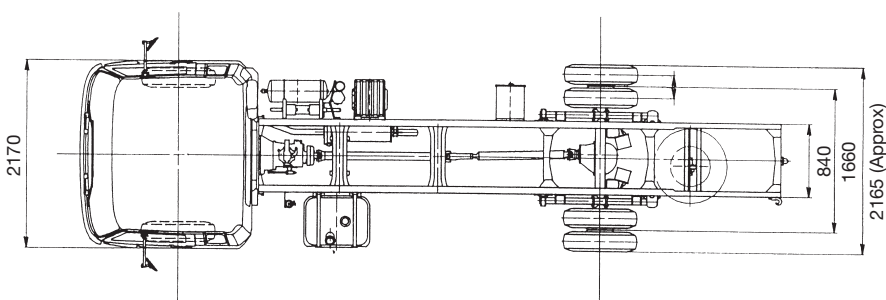
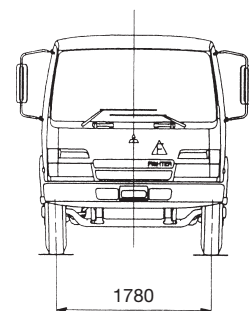
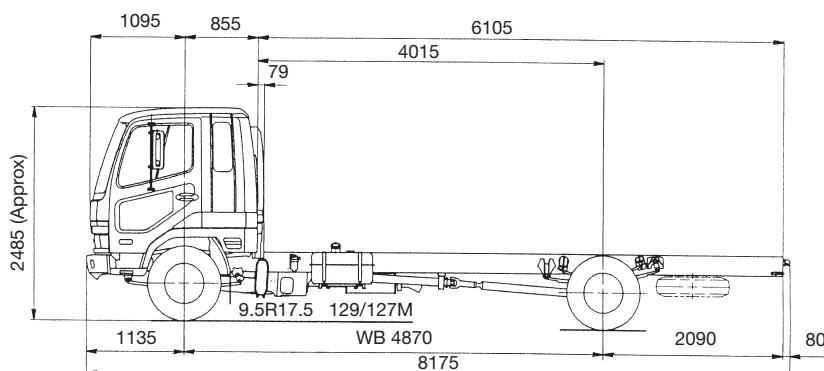

A policy of continual improvement means that specifications detailed in this brochure are subject to change without notice. Your Mitsubishi FUSO Dealer will be able to confirm the exact current specifications.

