

# FIGHTER 220

## 6x2 FU220R5

*NOMINAL PAYLOAD	WB	KERB WEIGHT EST.	GVM	GCM	CODE
14T	6210mm	5990kg	22000kg	25000kg	FM657MSRFBA

\* Subject to weight of body fitted

PERFORMANCE	
Maximum Speed:	111km/h
Gradeability at GVM:	26.4%
Gradeability at GCM:	22.5%
Minimum Turning Radius:	9.5m (kerb to kerb)

ENGINE	
<b>Model:</b>	<b>6D16-2AT7</b>
Configuration:	6 cyl in line
Type:	Turbo, 4 cycle direct injection
Displacement:	7545cc
Bore:	118mm
Stroke:	115mm
Power (JIS):	164kW (220ps) @ 2800rpm
Torque (JIS):	637Nm (470lb/ft) @ 1400rpm
Maximum Engine Speed:	3000rpm
Compression Ratio:	18.0:1
Oil Cooler:	Plate type – water cooled
Dry Weight:	507kg

FUEL	
Pump:	Bosch 'A' type
Governor:	All speed type
Tank Capacity:	200 litres
Filter:	In line filter with water separator
Air Cleaner:	Dry paper type
Fuel Cap:	Lockable

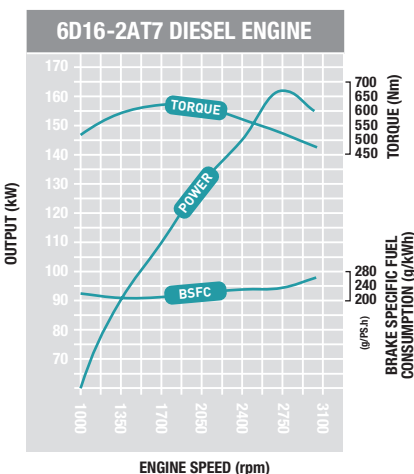

COOLING	
Fan:	6 blades – 520mm outer diameter
Fan Drive:	Viscous
Radiator:	Corrugated fin type with header tank

ELECTRICAL	
Voltage:	24v
Alternator Capacity:	35 amp
Starter Capacity:	4.5kW
Battery:	2 x 12v, 100Ah/20hr

CLUTCH	
<b>Model:</b>	<b>C6W35</b>
Diameter:	350mm
Type:	Single dry plate
Operation:	Air/hydraulic control
Facing Area:	582 x 2 sq cm
Facing Material:	Woven
Facing Thickness:	4.5mm

TRANSMISSION	
<b>Model:</b>	<b>M8S2x5</b>
No of Speeds:	10 forward 2 reverse
1.	Constant mesh 10.060
2.	Synchromesh 7.767
3.	Synchromesh 5.894
4.	Synchromesh 4.551
5.	Synchromesh 3.466
6.	Synchromesh 2.676
7.	Synchromesh 2.055
8.	Synchromesh 1.587
9.	Synchromesh 1.295
10.	Synchromesh DIR
Reverse 1.	Constant mesh 10.002
Reverse 2.	Constant mesh 7.722
Control:	Floor shift mechanical remote with air assistance & air operated high/low splitter

PROPELLER SHAFT	
Type:	P11 tubular steel with centre bearing
Universal Joint:	Needle roller bearing

REAR AXLES	
<b>Front Rear Axle</b>	<b>D8H</b>
Type:	Single reduction-hypoid
Design Capacity:	10200kg
Maximum Operating Capacity:	10200kg
Ratio:	5.142:1
<b>Lazy Axle</b>	
<b>Model:</b>	<b>Hendrickson HTA11</b>
Type:	Solid drawn torsion beam
Capacity:	11360kg
Maximum Combined Operating Capacity Restricted by Suspension:	18000kg

FRONT AXLE	
Type:	F070T reverse Elliot
Design Capacity:	6300kg
Maximum Operating Capacity:	6300kg

STEERING	
Type:	Power assisted – ball & nut
Gear Ratio:	21.6:1
Steering Wheel Diameter:	480mm
Steering Column:	Tilt & telescopic adjustable

BRAKES	
Type:	Full air 'S' cam
Size:	• Front: 410 x 150mm • Front rear: 410 x 200mm • Rear rear: 410 x 178mm
Total Lining Area:	8484 sq cm
Park Brake:	Spring
Auxiliary:	Exhaust
Compressor:	Single cylinder
Displacement:	340cc
Air Dryer:	Standard

SUSPENSION	
Type Front:	Long taper leaf
Size:	1400 x 80 x 19mm – 4
Type Rear:	HAS series air ride
Model:	Hendrickson HAS400-B402A
Shock Absorbers:	Double acting front & rear

CHASSIS	
Type:	Channel section with rivetless top flange
Size:	280 x 90 x 8mm
Width:	840mm
Towing Hook:	Rear
<i>Refer to FUSO bodybuilder guidelines on web site <a href="http://www.mmnztruckdvwg.co.nz">www.mmnztruckdvwg.co.nz</a> before mounting a body or modifying the chassis.</i>	

KERB WEIGHT		
Front:	Rear:	Total:
2735kg	3255kg	5990kg
<i>Includes coolant, oils, 20 litres fuel.</i>		

### FIGHTER 220 6X2 FU220R5



## WHEELS & TYRES

Number:	11
Studs:	10
Size:	22.5 x 8.5-165 offset – 12T
Tyre Size:	11R – 22.5
Tyre Type:	Tubeless steel radial

## CAB FEATURES

Construction:	All steel forward control
Type:	Manual tilt 44 deg
Mounting:	Fully isolated 3 point
Colour:	Natural White (W31)
Windscreen:	Laminated
•	Lift-up front maintenance panel
•	Transom window on LH door
•	Roof spoiler mounting points (max weight 50kg)
•	Front air dam

## DIMENSIONS

Wheel Base (WB):	6210mm
Overall Length (OAL):	9405mm
Cab to Axle (CA):	5465mm
Cab to End of Frame (CE):	7335mm
Rear Overhang (ROH):	1870mm
Overall Height (OAH):	2680mm
Overall Width (OAW):	2370mm
Front Track (FT):	1915mm
Rear Track (RT):	1845mm
Chassis Height at Rear Axle:	1020mm

## INSTRUMENTS

### Gauges:

- Speedometer with odometer & trip meter
- Tachometer
- Air pressure
- Fuel
- Water temperature

### Warning Lamps:

- Brake fluid level
- Park brake
- Oil pressure/filter blockage
- High beam
- Turn indicator
- Glow plug indicator
- Exhaust brake
- Engine oil level
- Vacuum pressure
- Alternator
- Air pressure/dual circuit
- Low oil pressure/filter blockage
- Engine overheat/low coolant level
- Door open
- Cab tilt

### Warning Buzzers:

- Air pressure
- Oil pressure
- Engine overheat/low coolant level

## OPTIONAL EQUIPMENT

### Live Drive PTO:

- Max output 295Nm
- Output speed 0.628 x engine rpm
- Rotation opposite engine

## CAB EQUIPMENT

### Exterior:

- Halogen headlamps
- Fog lamps in bumper
- Orange roof lamps x 4
- Heated rear vision mirrors
- Windscreen wipers: 2 speed & intermittent

### Interior:

- Fully trimmed
- Floor carpet with driver's mat insert
- Seating capacity for 3
- Seats: Driver: Air suspension, 32 stage reclining, 11 stage sliding, front & rear height adjuster, lumbar support, headrest, fabric trim
- Centre: Low back with fabric trim, forward folding
- LH: Fixed base, 32 stage reclining, headrest, fabric trim
- Seat Belts: 2 x ELR lap sash, semi integrated type, 1 x lap
- Centre floor console
- Console on back of centre seat
- Glove box x 2
- Door pockets
- Cup holders
- Overhead console pockets
- Sunvisors x 2
- Factory air conditioning
- Heater/demister
- Central locking
- Power windows
- AM/FM radio cassette with clock & 2 speakers
- Steering lock
- Key operated stop/start
- Engine idle speed control
- Cold start switch
- Reverse warning buzzer
- Hazard warning switch
- Interior spot lights
- Cigarette lighter & ash tray
- Electric horns
- Tool kit & jack
- Chassis mounted tool box

# FIGHTER 220

## 6x2 FU220R5

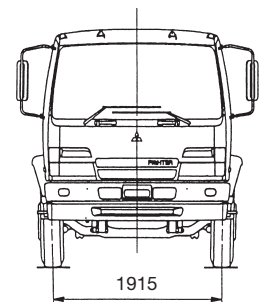
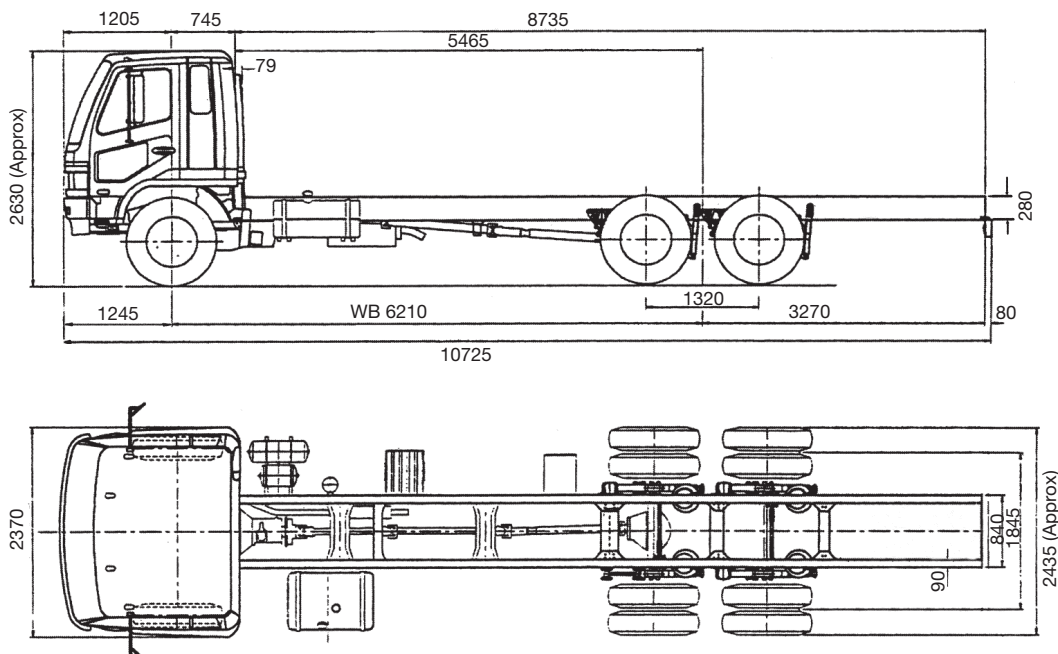

A policy of continual improvement means that specifications detailed in this brochure are subject to change without notice. Your Mitsubishi FUSO Dealer will be able to confirm the exact current specifications.

