

MEDIUM WHEELBASE

FIGHTER FN2428

6x4 • MANUAL OR ALLISON AUTO



GVM:
23,500kg



Power / Torque:
207kW / 802Nm



Wheelbase:
4,300mm (K) / 5,650mm (R)

- 30,000km service intervals
- Light tare - 12T nominal payload
- Isringhausen driver's seat
- High fuel-efficient engine

SPECIFICATIONS - FIGHTER FN2428 MWB

MODEL

6x4 FN2428	9 SP.	MAN	STEEL SUSP.	FN62FK2RFAK
6x4 FN2428	6 SP.	AUTO	STEEL SUSP.	FN62FK2RFAM
6x4 FN2428	6 SP.	AUTO	STEEL SUSP.	FN62FR2RFAM

WHEELBASE (mm)

4,300 (K)
4,300 (K)
5,650 (R)

GVM (kg) (optional)

23,500 (18,000)
23,500 (18,000)
23,500 (18,000)

GCM (kg)

34,000
34,000
34,000

ENGINE

Engine Version	FUSO 6M60-9AT2 Diesel
Configuration	6 Cyl. In-line OHC, 4-Valve
Type	Variable Geometry Turbo Charged Air to Air Intercooler
Displacement	7.5 litre (7,545cc)
Power ECE Nett	199kW @ 2500rpm
Torque ECE Nett	785Nm @ 1100-2400rpm
Power (JIS Gross)*	207kW (281ps) @ 2500rpm
Torque (JIS Gross)*	802Nm (592lb/ft) @ 1100-2400rpm
Maximum Engine Speed (rpm)	2900
Compression Ratio	16.0:1
Cooling System/Oil Cooler	Water cooled with Viscous fan, 23.0L capacity. Engine oil cooler
Air Cleaner	Paper Element Type with Restrictor Indicator. Vertical Intake Mounted on Clean Air Side (RH)
Cold Start Preheat	Standard
Emission Control	Selective Catalytic Reduction (SCR) after-treatment system (BlueTec), Positive Crankcase Ventilation (PCV)
Emission Level	Euro 5 (ADR 80/03)

*Calculated

6M60-9AT2

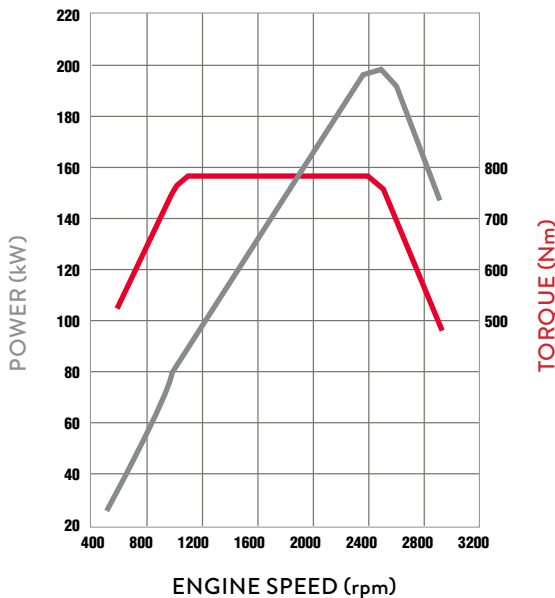

FUEL

Injection System	DENSO Common Rail System Electronically Controlled Direct Injection	
Tank Type	K Wheelbase	R Wheelbase
	Rectangular Steel Tank with Locking Cap	Rectangular Alloy Tank with Locking Cap
Fuel Capacity (L)	200	400
AdBlue Exhaust Fluid Capacity (L)	40	40

ELECTRICAL

Voltage	24V Negative Earth
Alternator Capacity	24V-80 amp
Battery Specification	Heavy Duty 2 x 12V, 100Ah/20hr
Headlamp Type	Halogen 2 x 70W/75W

CLUTCH

	Manual
Clutch Model	FUSO C7M38
Type	Single Plate Cerametallic 380mm
Operation/Specification	Air Assisted Hydraulic

TRANSMISSION

	Manual	Auto	
Version	Eaton Manual ES-11109 (Fuso Code M060S9)	Allison Automatic MD3500 (M100A6)	
Type/Speeds	9 Speed	6 Speed	
Features	Synchromesh 1L-4H	Generation 5 Control Systems	
Ratios	Low Range Low: 12.64 1st: 8.81 2nd: 6.55 3rd: 4.77 4th: 3.55	High Range 1st: 2.48 2nd: 1.85 3rd: 1.34 4th: 1.00 Rev: 13.21	1st: 4.593 2nd: 2.257 3rd: 1.535 4th: 1.000 5th: 0.749 6th: 0.651 Rev: 4.999
Torque Converter/ Stall Torque Ratio	N/A	TC415/2.35	
Automatic Transmission Fluid Cooling	N/A	2 Chassis Mounted Coolers (LH and RH Side)	
PTO Opening	LH Side and Rear	4 o'clock and 8 o'clock	

PROPELLER SHAFT

Type	P140/P8
Universal Joint	Needle Roller

FRONT AXLE

Axle	FUSO F650T "I" Beam
Design Capacity (kg)	6,500
Max Operating Capacity (kg)	6,500

FRONT SUSPENSION

Type	Taper Leaf with Double Acting Shock Absorbers
Size (mm)	1,400 x 80 Leaves

REAR AXLE

Type	Full Floating Hypoid, Tandem Drive with Inter-Axle Diff Lock	
Axle Version	FUSO D10HT/10H	
Design Capacity (kg)	21,600	
Max Operating Capacity (kg)	21,600	
Ratio	Manual	Auto
	5.142:1	6.166:1

SPECIFICATIONS - FIGHTER FN2428 MWB

REAR SUSPENSION

Type	Mechanical Suspension
Details	Long Taper Leaf, 6 Rod Trunion
Size Main Leaves (mm)	1,320 x 90

STEERING

Power Assisted	Tilt/Telescopic Adjustable Steering Wheel
----------------	---

BRAKES

Type	Full Air, Dual Circuit, FUSO Taper Roller, Automatic Brake adjustment, ABS
ASR (Traction Control)	Yes (Not available on auto model)
Size Front/Rear (mm)	410 x 150 / 410 x 200
Park Brake	Rear Wheel Spring Actuated
Auxiliary	Exhaust Brake
Compressor	Water Cooled, 340cc Single Cylinder with air dryer

WHEELS AND TYRES

Wheel Type	10, Single Piece Steel Disc
Wheel Size	22.5 x 8.25DC-165-13t
Wheel Stud Pattern	10 stud 335mm PCD
Tyre Size All	11R22.5

CHASSIS

Type	Reinforced Parallel Channel
Size (mm)	280 x 90 x 8.0
Width (mm)	851 (includes outer frame reinforcement)

INSTRUMENTS

Gauges	Speedometer with Odometer, Tachometer Air Pressure (2), Fuel Level, Water Temperature
Colour Information Display	Fuel Consumption, Service Indicators Hour Meter and Tripmeter

STANDARD FEATURES

Airbag	Driver's Air Bag and Seat Belt Pre-tensioner
Hill Start System	Yes (Not available on auto model)
Cab Cooling and Heating	Air Conditioner / Heater / Demister
Accessory Power	24V Accessory Power Outlet / Cigar Lighter
Driving	Keyless Central Locking Electric Windows; Cruise Control LH Transom Window AM/FM CD + USB + AUX + Bluetooth Hands Free
Driving (continued)	Cup Holders (4), Rear Quarter Glass Fluorescent Cabin Lamp and Interior Reading Lamps, Engine Idle Speed Control

STANDARD FEATURES (continued)

Storage	Centre Seat Storage Console, Rear Bunk Storage Pocket, Dash Storage Tray 2 DIN Glove Compartment, 1 Single and 1 Double DIN Slot for Accessor, Overhead Storage Pocket with Lid RH Door Storage Pocket
Cab: External	Roof Mounting Points (max. static load 70kg) Front End-Outline Marker Lamps
Chassis	Chassis Mounted Tool Box Reverse Warning Buzzer

CAB FEATURES

Type	All Steel Forward Control Manual Tilt 44 deg.
Mounting	Hydroelastic Susp. 4 Point
Colour	Natural White (W31)
Interior	Fully Trimmed
Windscreen	Laminated Tinted
Windscreen Wipers	2 Speed + Intermittent Cycle with Integrated Washer Nozzles
Door	90 degree Opening Angle
Rear Vision Mirrors	Remote Control / Heated with Convex Spotter (Both Sides)
Seating Capacity	3
Seat Belts	Lap Sash Belts for Outside Seating Positions Lap Belt for Centre Seat
Seat (driver)	ISRI Air Suspension with Auto Levelling, Height, Tilt and Dampening Adjustment Integral Headrest and Fabric Trim
Seats (passenger)	Centre: Low Back with Fabric Trim and forward folding; Far Passenger: Fixed Base with Reclining Seat Back, Integral Headrest and Fabric Trim

SERVICE INTERVALS

Please contact your nearest Fuso dealer for details

WARRANTY

36 months or 200,000km (whichever occurs sooner)
Subject to terms and conditions in the Fuso Warranty Booklet

PERFORMANCE

	Manual	Auto
Turning Circle (kerb to kerb - metres)	15.6	K Wheelbase 15.6 R Wheelbase 18.0
Electronically Speed Limited to:	100km/hr	100km/hr
Engine Speed (rpm) at 90km/hr (top gear)	2,185	1,895
Gradeability at Rated GVM (theoretical)*	37%	36%
Gradeability at Rated GCM (theoretical)*	24%	24%

Notes *This is theoretical performance only. Actual performance may vary under different condition

KERB WEIGHTS AND MAX AXLE LOADS (kg)

Model		Vehicle Ratings**		Max Axle Loadings**		Kerb Weights*		
		GVM	GCM	Front	Rear	Front	Rear	Total
6x4 FN2428 9 Sp. Man Steel Susp.	FN62FK2RFAK	23,500	34,000	6,500	21,600	3,035	3,650	6,685
6x4 FN2428 6 Sp. Auto Steel Susp.	FN62FK2RFAM	23,500	34,000	6,500	21,600	3,080	3,725	6,805
6x4 FN2428 6 Sp. Auto Steel Susp.	FN62FR2RFAM	23,500	34,000	6,500	21,600	3,330	3,810	7,140
6x4 FN1828 9 Sp. Man Steel Susp.	FN62FK2RFAK(D)	18,000	34,000	6,500	21,600	3,035	3,650	6,685
6x4 FN1828 6 Sp. Auto Steel Susp.	FN62FK2RFAM(D)	18,000	34,000	6,500	21,600	3,080	3,725	6,805
6x4 FN1828 6 Sp. Auto Steel Susp.	FN62FR2RFAM(D)	18,000	34,000	6,500	21,600	3,330	3,810	7,140

* Weights (est.) includes 10L fuel and spare wheel and are subject to 2.5% variation (+/-)

** Vehicle ratings and max axle loadings may be limited by local regulations.

SPECIFICATIONS - FIGHTER FN2428 MWB

DIMENSIONS (mm)

	K Wheelbase	R Wheelbase		K Wheelbase	R Wheelbase
Wheelbase	4,300	5,650	Width Front Track	1,925	1,925
Length Overall	7,515	9,695	Width Rear Track	1,850	1,850
Height Overall	2,675	2,670	Width Frame	851	851
Width Overall	2,470	2,470	Height Frame at Rear Axle	1,037	1,035
Width Rear Axle	2,470	2,470			

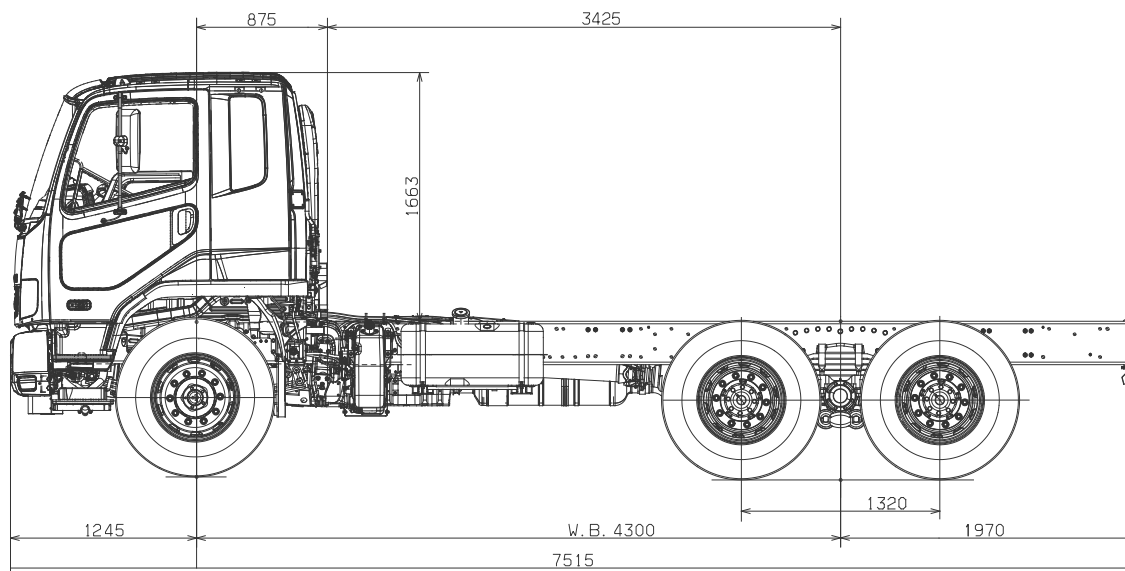

FIGHTER FN2428 – 'K' WHEELBASE

1000
UNIT: mm 20mm=1m

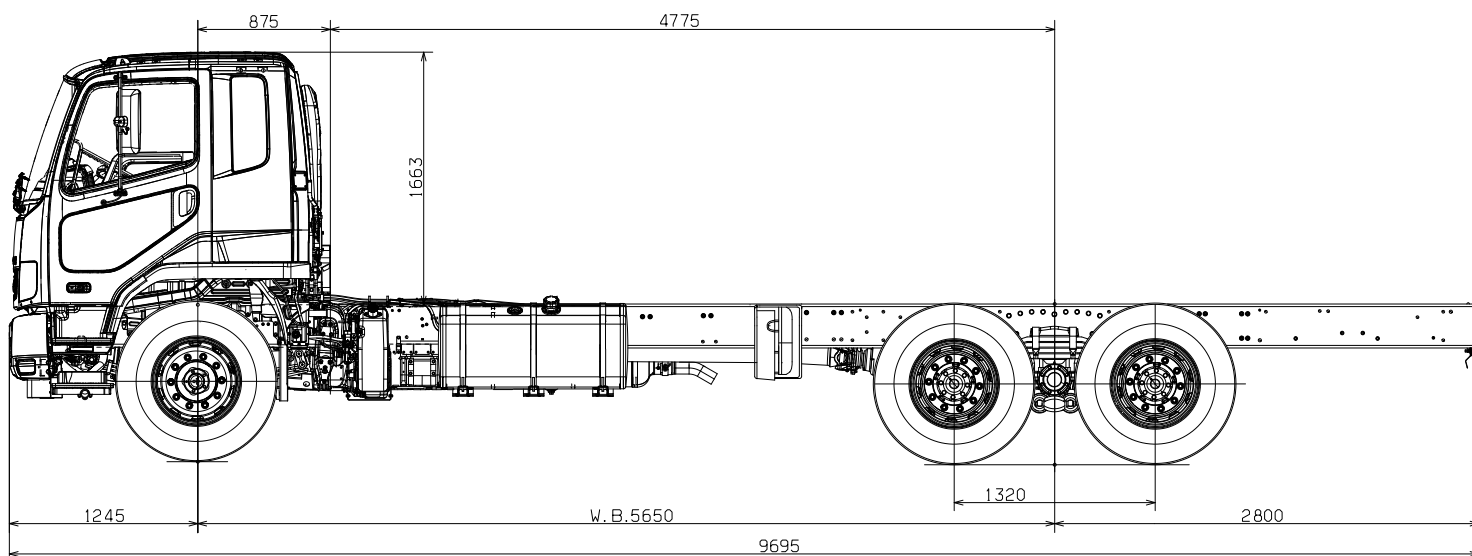

FIGHTER FN2428 – 'R' WHEELBASE

1000
UNIT: mm 20mm=1m

Scale = 1:50 (20mm = 1 metre). This scale is accurate when used on the original spec sheet, be aware that enlarging these illustrations can alter the scale and cause incorrect measurements. Fuso New Zealand and its authorised dealers always recommend customers seek professional advice from independent sources before commencing any engineering activities.

A policy of continual improvement means that specifications detailed in this brochure are subject to change without notice. Contact your authorised Fuso dealer to confirm current specifications. Fuso is a registered trademark of Mitsubishi Fuso Truck & Bus Corporation. Copyright © Fuso NZ (2017)