

CANTER EURO 5.0T

GVM	GCM	POWER	W/BASE	CODE
8550kg	12050kg	184ps (JIS Gross)	3850mm	FECX1GR3WFAD



PERFORMANCE

Maximum Speed: 130 Km/h
 Gradeability at Rated GVM: 32% @ GVM 8550kg
 Turning Circle (kerb to kerb): 13.6 Mtrs

ENGINE

Mitsubishi 4P10-7AT6 (Euro V)

Description: 4 Cylinder
 Configuration: Inline-DOHC 4 Valve
 Type: Variable Geometry Turbo
 Charged with Air to Air Intercooler
 Displacement: 2,998cc
 Power (DIN Nett): 129kw @ 2860 to 3500rpm
 Torque (DIN Nett): 430Nm @ 1600 to 2860 rpm
 Compression Ratio: 17.5:1
 Oil Cooler: Plate Type, Water Cooled

4P10-7AT6

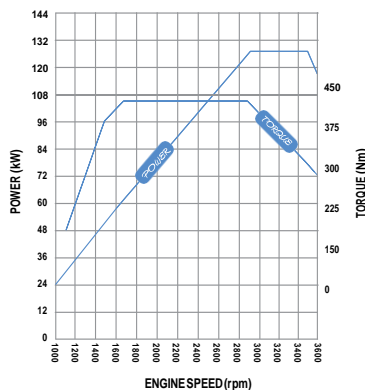

FUEL

Pump: Bosch Common Rail
 Governor: Electronic
 Filtration: Main Filter with Water Separator
 Fuel Capacity: 100 Litre/Lockable
 Air Cleaner: Dry Paper Element/Vertical Intake

EMISSION SYSTEMS

Emission Standard: Euro V + Enhanced Environmentally Friendly Vehicle (EEV)

Diesel Particulate Filter (DPF) Exhaust with BLUETEC® SCR After Treatment System
 12L Adblue tank by fuel tank
 DPF Status on dash display

COOLING

Fan: 460mm Diameter with 9 Blades
 Fan Drive: Viscous Coupling
 Radiator: Corrugated Fin with expansion tank

ELECTRICAL

Voltage: 12 volt
 Alternator Capacity: 110 amp
 Battery Capacity: 2 x 12V 90AH
 Headlamp: Halogen 55/60W
 Fog lamp: Front Bumper

CLUTCH

Description: Fully Automated Wet Dual Clutch

TRANSMISSION

Description: FUSO Duonic M038S6 AMT
 No. of Speeds: 6
 Ratios:

- 1st: 5.397
- 2nd: 3.788
- 3rd: 2.310
- 4th: 1.474
- 5th: 1.000
- 6th: 0.701
- Rev: 5.397

 PTO Opening: LH side

PROPELLER SHAFT

Type: P3
 Universal Joint: Needle Roller

FRONT AXLE

Type: Reverse Elliot 'I' Beam
 Design Capacity: 3100kg
 Maximum Operating Capacity: 3100kg

REAR AXLE

Description: Mitsubishi D035H
 Type: Full floating Hypoid
 Design Capacity: 6000kg
 Maximum Operating Capacity: 6000kg
 Ratio: 6.166

STEERING

Type: Integral Power Assisted Ball
 Steering Wheel: Urethane with Airbag
 Steering Column: Tilt/Telescopic Adj

BRAKES

Type: Hydraulic Dual Circuit with ABS/EBD.
 Dual Caliper Ventilated Disc Front and Rear
 Brake Override safety system
 Size: F 235 x 40mm
 R 235 x 40mm
 Park Brake: Transmission Mounted
 Auxiliary: Exhaust Brake

FRONT SUSPENSION

Type: Semi-Elliptic Leaf Springs with Shock Absorbers & Stabilizer
 Size: 1150 x 70 x 10 - 3 leaf 11 - 2 leaf
 Capacity at Ground: TBA

REAR SUSPENSION

Type: Semi-Elliptic Leaf Springs with Shock Absorbers & Stabilizer
 Size: 1250 x 70 x 10 - 3 leaf
 11 - 2
 12 - 1
 Auxiliary: 880 x 70 x 16 - 3 leaf
 Capacity at Ground: TBA

CHASSIS

Type: Reinforced Taper Channel
 Size: 212 x 65 x 6mm
 Width: 850mm
 Tensile Strength: 540 mpa

WHEELS & TYRES

Wheel Type: Single piece tubeless rims
 Wheel Size: 17.5"
 Tyre Size: 215/75R17.5
 Spare & Tyre Carrier: YES



WIDE DOUBLE CAB

KERB WEIGHT (kg – estimated)

Front:	1735
Rear:	960
Total:	2695

Includes coolant, oils and 20 litres fuel.

DIMENSIONS (mm)

WheelBase:	3850
Overall Length:	6685
Cab to Axle:	2271
Rear Overhang:	1695
Overall Height:	2330
Overall Width:	1995
Track Front:	1675
Track Rear:	1670

CAB FEATURES

All Steel Forward Control. ECE R29 Safety Cab

Type:	Fixed Double Cab
Mounting:	Hydroelastic 4 point
Colour:	White W31
Interior:	Fully Trimmed
Windscreen:	Laminated and Tinted
Windscreen Wipers:	2 Speed-Intermittent with Integrated Washer Nozzles
Rear Vision Mirrors:	1 Internal 2 x External Convex-Heated
Seating Capacity:	7
Seat Belts:	Driver – Height adjustable Driver's: 3 point ELR with tension reducer Front Passenger – ELR 3 point: 2 Point centre Rear Passenger – Outer position ELR 3 point Centre belts: 2 point
Driver Seat:	Suspension base, Fabric trim with built in headrest, lumbar support and armrest
Passenger Seat:	Flat folding 2 passenger bench type with left-hand headrest and fabric trim
Rear Seats:	Bench type, 4 person, fabric Headrest right and left sides

INSTRUMENTS

Gauges:

- Speedo with Odometer and Dual Trip Meter
- Tachometer
- Fuel Level
- Ad Blue Level Indicator

Warning Lights:

- High Beam
- Turn signal/Hazard warning
- Park Brake
- Exhaust Brake
- Engine Pre-Heat
- Alternator
- Low Oil Pressure
- SRS Airbag
- Brake Pad Wear
- Immobilizer
- Seat Belts
- DPF
- AMT Oil Temp
- AMT Fault
- Engine Check Light
- ABS Check Light

SWITCHES

- Fog Lamps
- Fluorescent Cab Lamp
- Heated Exterior Mirrors
- DPF Regeneration switch
- Transmission Economy Mode Switch
- Hazard Lights



CAB EQUIPMENT

- Driver's airbag
- Electric Windows with one touch drivers
- Keyless Central Locking
- Door side impact beams
- Tinted side and rear glass
- Heater-Demister/Air-conditioning
- Interior sunvisors LH/RH
- AM/FM CD radio with 2 speakers
- Fluorescent Cabin Lamp
- Interior Dome Lamp with Delay Function
- Front Step lamps
- Cab Front Outline Marker Lights
- Cigar Lighter
- Electric Horn
- Reverse Warning Buzzer
- Tool Kit
- Overhead Parcel Shelves LH/RH
- Lower Dash Document Holder
- Lockable Glovebox (Excludes dual airbag models)
- Engine access panel

MULTI FUNCTION DISPLAY

- Calendar/Time
- Meter and Gauge Illumination
- Service Reminders
- DPF Level indication
- Fuel Consumption Indication
- Diagnostic Trouble Code Indication
- Coolant Temperature Gauge
- Gear Position Indicator
- Odo and Dual trip meter

CANTER EURO 5.0t

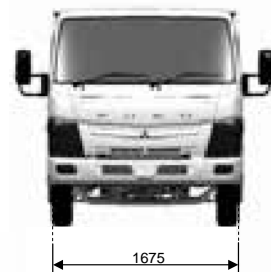
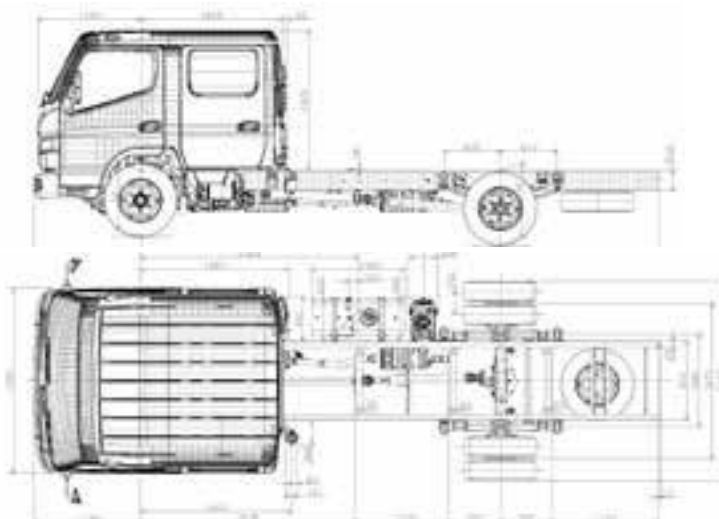

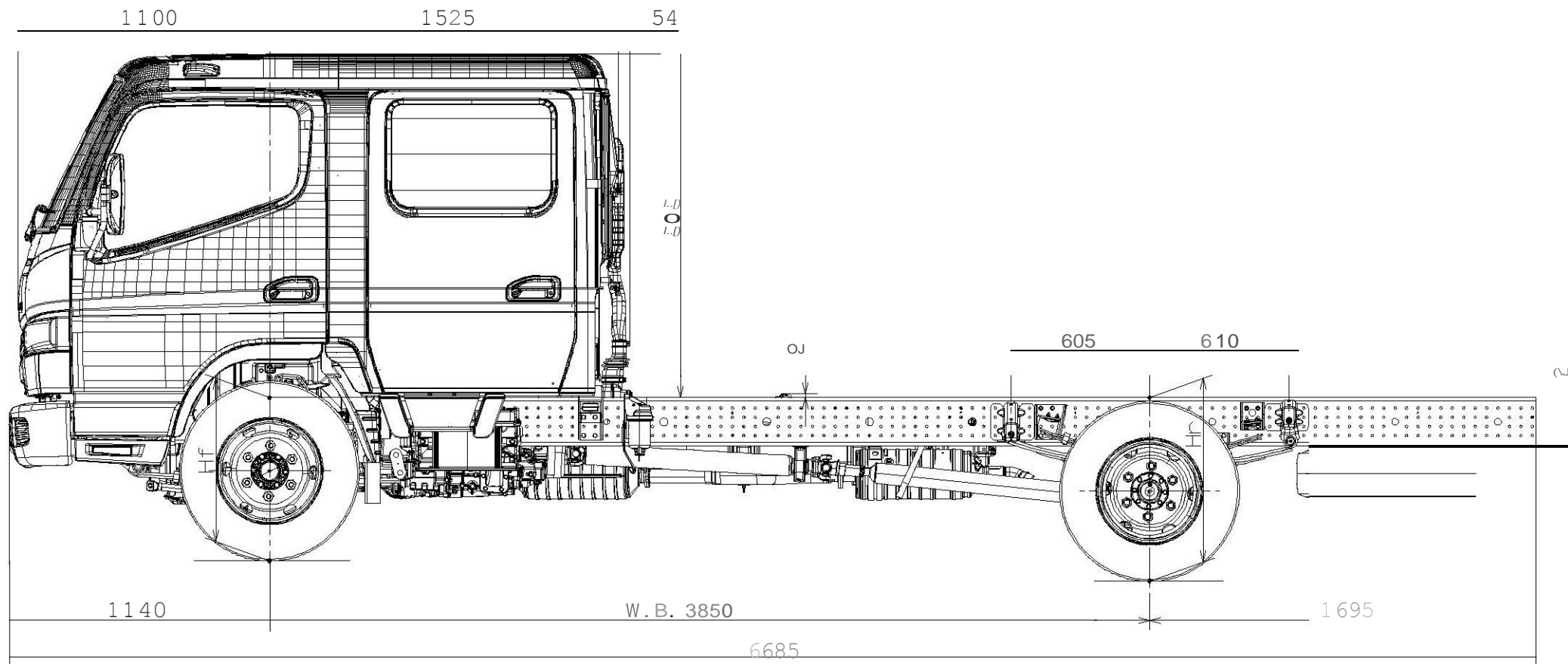
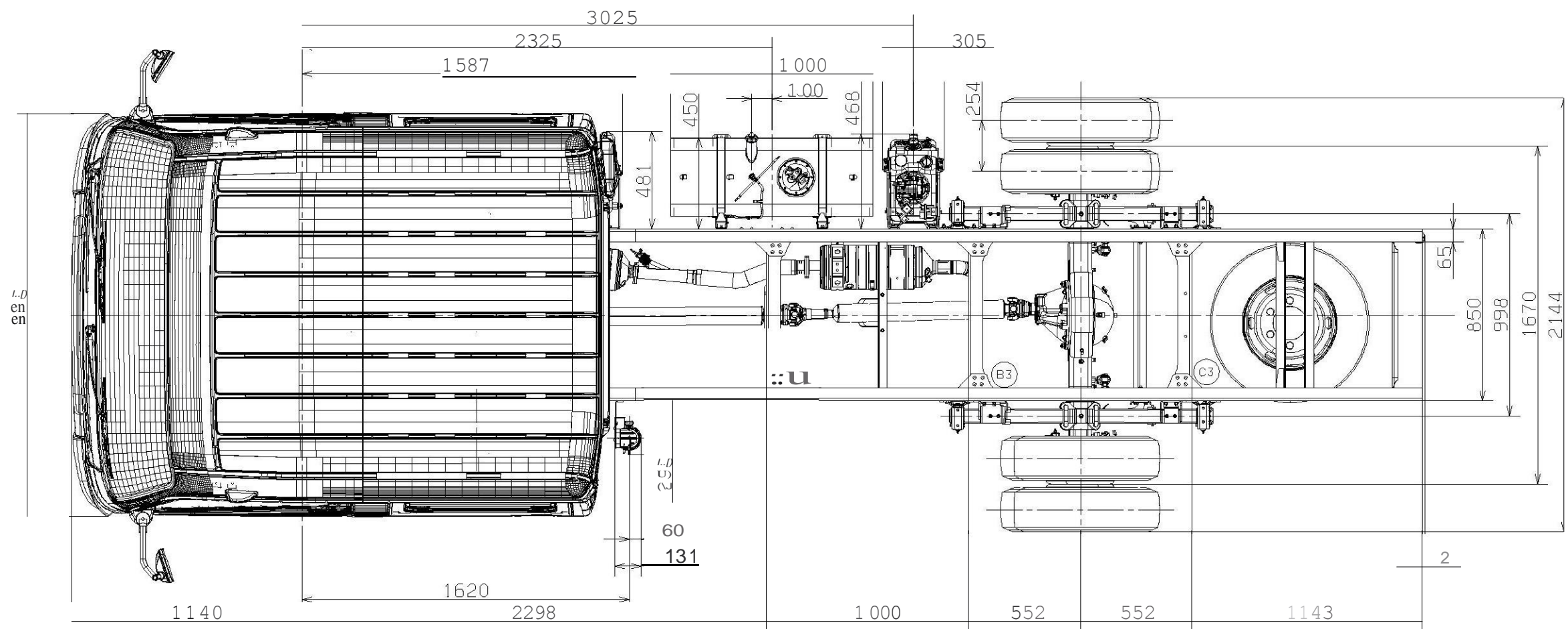

CHASSIS CAB
DRAWINGS

FECX1GR3WFAO

UNIT : mm
SCALE : 1/25