

# FUSO HEAVY



CONFIGURATION	GVM	GCW	KERB WEIGHT	W/BASE	CODE
8X4	30.8T	55.0T	8625KG	5870MM	FS2S5VFAB

## PERFORMANCE

Maximum Speed:	117 km/hr
100km/hr speed limiter available	
Gradeability at Rated GCM:	29.5%
Turning Radius (kerb to kerb):	10.8 m

## ENGINE

### Fuso OM457-T5 12L (Euro V)

Configuration:	Inline 6 Cylinder
Type:	OHV, 4 Valve, Waste Gate Turbo with Intercooler
Displacement:	11967cc
Bore x Stroke:	128mm x 155mm
Power (DIN nett):	335kW @ 1900rpm (JIS Gross: 470ps*)
Torque (DIN nett):	2200Nm @ 1100rpm (JIS Gross: 1644lb/ft*)
Maximum Engine Speed:	2200rpm
Compression Ratio:	18.5:1
* Calculated	

## OM457 ENGINE PERFORMANCE

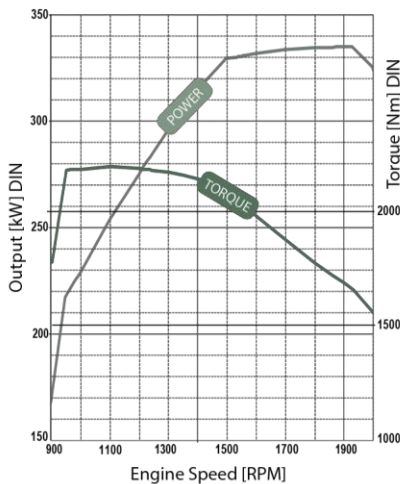

## FUEL

Pump:	Bosch Unit Injectors
Governor:	Electronic
Filtration:	Main filter with water separator
Fuel Capacity:	400L Steel tank with lockable cap
Air Cleaner:	RHS snorkel with single element and electronic dust indicator
Cold Start Preheat:	Standard

## EMISSION SYSTEM

Emission Standard:	Euro V
Box muffler LHS. Exhaust with BLUETEC® SCR After Treatment System. 40L ADBLUE tank with on dash gauge.	

## COOLING

Fan:	750mm diameter with 8 Blade
Fan Drive:	Viscous Clutch
Radiator:	Aluminium

## ELECTRICAL

Voltage:	24 volt neg earth
Alternator Capacity:	24v - 80 amp
Heavy Duty Batteries Capacity:	2 x 12v, 150Ah/20hr

## CLUTCH

<b>Description:</b>	<b>C12W43P</b>
Type:	Single dry plate 430 mm Woven facing material
Operation:	Fully Automated with Hill Start Assist

## TRANSMISSION

### Model: FUSO INOMAT II G230-12 AMT (2 Pedal Type)

No. of Speeds:	12
Ratios:	– 1st: 11.672
	– 2nd: 9.101
	– 3rd: 7.055
	– 4th: 5.501
	– 5th: 4.400
	– 6th: 3.430
	– 7th: 2.652
	– 8th: 2.068
	– 9th: 1.603
	– 10th: 1.250
	– 11th: 1.000
	– 12th: 0.779
Reverse:	High: 9.101:1 Low: 11.672:1

Control:	INOMAT 2 Automated shift with auto and manual shift modes and Hill Start Assist
Additional Modes:	Start gear select, Slow Manoeuvre, Economy, Reverse high/low
Oil Cooler:	T/M oil cooler (air cooling type)
PTO Opening:	LHS and Rear mounting

## PROPELLER SHAFT

Type:	Main: GW5E220 with guard
	Interaxle: P12

## FRONT AXLE

Type:	F900T
Maximum Operating Capacity:	14,200kg (Subject to suitable tyres & certification)

## STEERING

Type:	Integral Power Assisted ball & nut
Steering Wheel:	Urethane with air bag
Steering Column:	Tilt & Telescopic adjust

## REAR AXLE

Description:	D10HT/D10H with Interaxle diff lock
Type:	Single Reduction Hypoid
Design Capacity:	21600kg
Maximum Operating Capacity:	21600kg
Ratio:	4.222

## BRAKES

Type:	Full air taper roller drum brakes with auto adjust ABS & ASR Traction control
Size:	F 410 x 150mm R 410 x 200mm
Park Brake:	Spring on both rear axles
Engine Brake:	4 stage Powertard with Exhaust Brake and Shift Down
Retardation Power:	320ps @ 2300 rpm
Compressor:	636cc with air dryer
Air Tanks:	Alloy

## FRONT SUSPENSION

Type:	Long Taper Leaf
Size:	1500 x 90 x 23mm - 3
Capacity at Ground:	7280kg per axle
Shock Absorbers:	Double acting
Roll Bar:	Front axle

## REAR SUSPENSION

Type:	Long Taper Leaf
Size:	1320 x 90 x 23mm - 3
Capacity at Ground:	22,500kg

### Optional Air Suspension

Type:	FUSO airbag with underslung arm
Size:	250mm diameter bags
Capacity at Ground:	22000kg
Shock Absorbers:	Double acting front & rear

## CHASSIS

Type:	Super Frame parallel channel with tapered rear overhang
Size:	300 x 90 x 7mm
Width:	840mm
Tensile Strength:	540MPa

## WHEELS & TYRES

Wheel Type:	Alcoa Forged Alloy
Wheel Size:	8.25 x 22.5 - 165-23T
Wheel Stud Pattern:	10 Stud ISO
Tyre Size:	275/70R22.5
Spare Tyre:	No

## KERB WEIGHT (KG – ESTIMATED)

	Standard	Opt Air Suspension
Front	5720	5665
Rear	3080	2960
Total	8800	8625

Includes coolant, oils and 20 litres fuel.

## DIMENSIONS (MM)

Wheel Base:	5870
Overall Length:	10140
Cab to Axle:	5170
Rear Overhang:	2867
Overall Height:	3640
Overall Width:	2490

## OPTIONAL EQUIPMENT

- 4.625 - Front 295/85R22.5 Rear 11R22.5
- Reverse camera and navigation

## MULTI FUNCTION DISPLAY

- Calendar/Time
- Service Reminders
- Snow Mode - Low speed manoeuvring
- Fuel Consumption Indication
- Diagnostic Trouble Code Indication
- Gear Position Indicator
- Odo and Dual trip meter
- Engine Oil level check
- Warning/indicator display
- AdBlue level indicator
- Hour Meter
- Maintenance Indicator

## CAB FEATURES

Construction:	All Steel Forward Control with high roof
Type:	Electric/Hydraulic 50 deg cab tilt
Mounting:	4 Point air suspension
Colour:	Natural White (W31)

Safety features:	European Safety Standard ECE-R29 90 degree opening doors with side intrusion bars
Lighting:	Projector headlamps with Fog lights in bumper
Interior:	Fully trimmed with rear mattress
Windscreen:	Laminated & tinted
Windscreen Wipers:	3 windscreen wipers with built in nozzles: 2 speed & intermittent
Rear Vision Mirrors:	Remote control & heated flat main mirror with heated convex spotters
Seating Capacity:	2
Seats:	Driver: ISRI air suspension with auto levelling, height, tilt and dampening adjustment Integral headrest & fabric trim Passenger: Fixed base, 18 stage reclining, headrest & fabric trim
Seat belts:	Pretensioner, ELR attached 3 points type

## INSTRUMENTS

### Gauges:

- Speedo with odometer and dual trip meter
- Tachometer and fuel level
- Dual air pressure gauge
- Water temperature meter

### Warning Lamps:

- Park Brake and Seat Belts
- Exhaust Brake/powerlard
- Alternator
- Low Oil Pressure/Oil Filter Blockage
- SRS Air Bag
- AdBlue level indicator
- Immobiliser
- AMT oil Temp
- Engine check light
- Interaxle diff lock
- Brake air pressure
- Cold start indicator
- Door Open
- Low coolant level
- Cab tilt indicator
- Air filter restriction
- Cruise Control
- ABS/ASR

## CAB EQUIPMENT

### Exterior:

- Halogen headlights & fog lamps in bumper
- Roof mounted white marker lights x2
- Lift-up front maintenance panel
- Transom window on LH door
- Side intrusion bars & Front Underrun Protection
- 1 piece door pressing with 90 deg opening
- Roof spoiler mounting points (max weight 50kg)

### Interior:

- Fully trimmed- Centre-Rear-Side Curtains
- Driver's air bag and seat belt pretensioner
- Large centre floor console with glove box
- Cup holder for driver
- Large overhead console boxes
- Tray under passenger seat
- Sun visors x 2
- Interior rear view mirror
- Opening rear quarter windows
- Grab handle on 'A' pillar
- Auto air conditioning with heater/demister
- Central locking and Keyless Entry System
- Power windows and Drivers auto up/down
- 6" Touch screen audio with Bluetooth, USB and DVD player with 2nd screen output.
- Engine idle speed control
- Cruise control
- Cold start switch
- Trailer brake hand control
- Hazard warning switch
- Reading lamps
- Fluorescent lamp
- Curtains
- Tool kit & jack
- Electric Horn
- Fluorescent Cab Lamp

## FUSO HEAVY

### 8X4

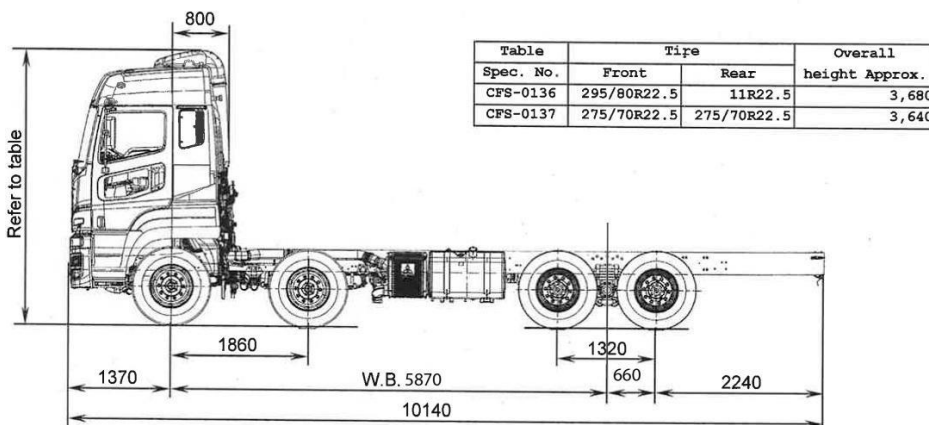

10.5 Chassis cab drawings

FS52SS5VFAB

FS470S2

